

# L 3500



*macchine edili ed agricole*  
S.r.l.  
**d DIECI**



# L 3500



## DETAILS

Concrete yield:..... 2,50 m<sup>3</sup>  
 Track:..... 2000 mm  
 Tyres:..... 12.5 x 18" for construction site  
 Total weight (empty - with loading shovel):..... 6150 Kg  
 Total weight (empty - without loading shovel):... 5900 Kg  
 Water tank capacity:..... 700 l  
 Loading shovel capacity:..... 500 l  
 Maximum speed:..... 27 km/h  
 Self-priming water pump  
 "CE" Marking



## TRANSMISSION

Variable capacity hydrostatic pump  
 Hydraulic engine with continuous automatic adjustment  
 Electro-hydraulic reversing gear, can be actuated with vehicle in motion  
 Servo controlled 2-speed gearbox



## CAB

Reversible driver's seat.  
 ROPS-FOPS approved.  
 Rear and front glasses - 2 windscreen wipers  
 Adjustable seat with seat belt.  
**Instrument system:** fuel level indicator - water and oil temperature light - battery charger.



## ENGINE

Model:..... IVECO NEF - 4 cylinders - Diesel NA  
 Maximum power:..... 60 kW (82 hp) at 2300 rpm  
 Displacement:..... 4485 cm<sup>3</sup>  
 Injection:..... direct  
 Cooling:..... water  
 Intake:..... natural



## DIFFERENTIAL AXLES

Steering types:..... 4 wheels / transversal / 2 wheels  
 Rear and front steering axles with planetary reduction gears.  
 Self-blocking front axle.  
 Hydraulic brake with oil-bath disks on 4 wheels.  
 Negative parking brake.



## DRUM ROTATION HYDRAULIC SYSTEM

Open circuit gear pump with drum rotation speed regulator.  
 Hydraulic coaxial geared motor.



## MIXING DRUM

3-side discharge by means of roller bearing fifth wheel  
 Drum lifting to facilitate discharge



## SAFETY DEVICES

Starting only with gear in neutral.

The information contained in this publication is merely indicative; the models described may be modified, without notice, by the manufacturer, drawings and photographs may refer to optional or particular equipment for other countries. For any further information, please contact DIECI premises at the address given below.



# L 3500



## GENERALIDADES

Rendimiento en hormigón armado:..... 2,50 m<sup>3</sup>  
 Distancia entre las ruedas:..... 2000 mm  
 Ruedas:..... 12.5 x 18" uso en obra  
 Peso total sin carga (con pala):..... 6150 Kg  
 Peso total sin carga (sin pala):..... 5900 Kg  
 Capacidad tanque agua:..... 700 l  
 Capacidad pala de carga:..... 500 l  
 Velocidad máxima:..... 27 km/h  
 Bomba agua de autocebado  
 Marca "CE"



## TRANSMISIÓN

Bomba hidrostática de caudal variable  
 Motor hidráulico de 2 velocidades con selección eléctrica  
 Inversor: electro-hidráulico accionable incluso con la máquina en movimiento  
 Cambio de 2 velocidades con servo mando



## CABINA

Puesto de conducción reversible.  
 Homologación ROPS -FOPS.  
 Asiento regulable con cinturón de seguridad.  
 Cristales delanteros y traseros - 2 limpiaparabrisas.  
**Instrumentos:** indicador de nivel combustible - luz testigo aceite y temperatura agua - carga batería.



## MOTOR

Modelo:..... IVECO NEF - 4 cilindros - Diesel NA  
 Potencia máxima:..... 60 kW (82 cv) a 2300 rpm  
 Cilindrada:..... 4485 cm<sup>3</sup>  
 Inyección:..... directa  
 Enfriamiento:..... por agua  
 Aspiración:..... natural



## PUNTES DIFERENCIALES

Tipos de viraje:..... 4 ruedas/transversal/2 ruedas  
 Eje delantero y trasero de dirección con reductores epicicloidales. Eje delantero con bloqueo automático.  
 Frenado hidráulico con discos en baño de aceite en las 4 ruedas.  
 Freno de aparcamiento negativo.



## SISTEMA HIDRÁUL. ROTAC. TAMBOR

Bomba de engranajes de circuito abierto con regulador de velocidad de rotación del tambor.  
 Motorreductor hidráulico coaxial.



## TAMBOR DE AMASIJO

Descarga trilateral mediante rotación sobre el tejuelo.  
 Elevación del tambor para facilitar la descarga.



## DISP. DE SEGURIDAD

Arranque sólo con la marcha en punto muerto.

Los datos presentados en este impreso son proporcionados a título indicativo; los modelos descritos pueden ser modificados sin previo aviso por el fabricante, los dibujos y fotografías pueden referirse a equipamientos opcionales o a equipamientos destinados a otros países. Para cualquier otra información, diríjase al domicilio de DIECI en la dirección al pie de la ficha.



# L 3500



## CARACTÉRISTIQUES

Rendement en béton:..... 2,50 m<sup>3</sup>  
 Entraxe des roues:..... 2000 mm  
 Pneus:..... 12.5 x 18" utilisation sur chantier  
 Poids total à vide (avec pelle de chargement):..... 6150 Kg  
 Poids total à vide (sans pelle de chargement):..... 5900 Kg  
 Contenance réservoir d'eau:.....700 l  
 Contenance pelle de chargement:..... 500 l  
 Vitesse maxi:..... 27 km/h  
 Pompe à eau autoamorçante  
 Marque "CE"



## TRANSMISSION

Pompe hydrostatique à débit variable  
 Moteur hydraulique à 2 vitesses - selection électrique  
 Inverseur: électro-hydraulique actionnable avec la machine en mouvement  
 Boîte à 2 vitesses avec direction assistée



## CABINE

Poste de conduite réversible.  
 Homologation ROPS – FOPS.  
 Glaces avant et arrière - 2 essuie-glace.  
 Siège réglable avec ceintures de sécurité.  
**Instruments:** témoin niveau carburant, témoin huile et température eau - Charge de la batterie



## MOTEUR

Modèle:..... IVECO NEF - 4 cylindres- Diesel NA  
 Puissance maximum:..... 60 kW (82 cv) à 2300 tpm  
 Cylindrée:.....4485 cm<sup>3</sup>  
 Injection:..... directe  
 Refroidissement:..... par eau  
 Aspiration:..... naturelle



## PONTS DIFFÉRENTIELS

Types de direction:..... 4 roues/transversal/2 roues.  
 Essieux avant et arrière de direction avec réducteurs épicycloïdaux.  
 Essieu avant avec auto-blocage.  
 Freinage hydraulique à disques à bain d'huile sur les 4 roues  
 Frein de stationnement négatif.



## INSTALLATION HYDRAULIQUE ROTATION TAMBOUR

Pompe à engrenages à circuit ouvert avec régulateur de vitesse rotation tambour  
 Motoréducteur hydraulique coaxial



## TAMBOUR D'ENROBAGE

Déchargement trilatéral par rotation sur bague  
 Soulèvement tambour pour faciliter le déchargement.



## DISPOS. DE SÉCURITÉ

Démarrage seulement au point mort.

Les données contenues sur cet imprimé sont fournies à titre indicatif; les modèles décrits sont susceptibles d'être modifiés, sans préavis, de la part du fabricant; les dessins et les photographies peuvent faire référence à des équipements en option destinés à d'autres pays. Pour toutes autres informations, s'adresser au siège DIECI à l'adresse qui se trouve en bas de la fiche.



# L 3500



## BAUEIGENSCHAFTEN

Betonaustragung:..... 2,50 m<sup>3</sup>  
 Radstand:..... 2000 mm  
 Bereifung:..... 12.5 x 18" für Baustelleneinsatz  
 Gesamtleergewicht (mit Ladeschaufel):..... 6150 Kg  
 Gesamtleergewicht (ohne Ladeschaufel):..... 5900 Kg  
 Fassungsvermögen Wasserbehälter:..... 700 l  
 Fassungsvermögen Ladeschaufel:..... 500 l  
 Max. Geschwindigkeit:..... 27 km/h  
 Selbstansaugende Wasserpumpe  
 "CE"- Kennzeichnung



## ANTRIEB

Hydrostatische Verstellpumpe  
 Hydraulik-Motor automatisch stufenlos verstellbar  
 Umschaltung: elektrisch-hydraulisch auch bei fahrender Maschine  
 Servogesteuerte 2-Gang-Schaltung



## KABINE

Umdrehbarer Fahrersitz.  
 Zulassung ROPS –FOPS.  
 Vordere und hintere Scheiben  
 2 Scheibenwischer - verstellbarer Sitz mit Sicherheitsgurt.  
**Instrumentenbrett:** Kraftstofffüllstandsanzeige - Kontrolllampe Öl und Wassertemperatur - Batterieladestand.



## MOTOR

Modell:.....IVECO NEF - 4 Zylinder - Diesel NA  
 Maximale Leistung:..... 60 kW (82 PS) bei 2300 U/min  
 Hubraum:..... 4485 cm<sup>3</sup>  
 Direkte Einspritzung  
 Wasserkühlung  
 Selbstansaugung



## DIFFERENTIALACHSEN

Lenkungstyp:.....4 Räder/Hundegang/2 Räder  
 Vordere und hintere Lenkachse mit Planetenuntersetzungsgetriebe; selbstsperrende Vorderachse.  
 Hydr. Scheibenbetriebsbremse im Ölbad auf 4 Rädern.  
 Standbremse mit negativer Betätigung.



## HYDRAULIKANLAGE TROMMELDREHUNG

Zahnradpumpe mit offenem Kreislauf und Trommelumlaufgeschwindigkeitsregler  
 Koaxiales hydraulisches Untersetzungsgetriebe



## MISCHTROMMELN

Dreiseitige Abladung über Spurfannenrotation.  
 Trommelhub zur Unterstützung der Entladung.



## SICHERHEITSEINRICHTUNG

Start nur im Leerlauf.

DIE ANGABEN IN DIESEM HANDBUCH HABEN NUR RICHTWERT. DER HERSTELLER DIECI S.r.l. BEHÄLT SICH DAS RECHT VOR, DIE BESCHRIEBENEN MODELLE OHNE VORANKÜNDIGUNG ZU ÄNDERN. DIE ZEICHNUNGEN UND FOTOS KÖNNEN SICH AUF OPTIONALAUSRÜSTUNGEN ODER FÜR ANDERE LÄNDER BESTIMMTE VORRICHTUNGEN BEZIEHEN. FÜR WEITERE INFORMATIONEN WENDEN SIE SICH BITTE AN DEN SITZ VON DIECI (ANSCHRIFT S. UNTEN).

# L 3500

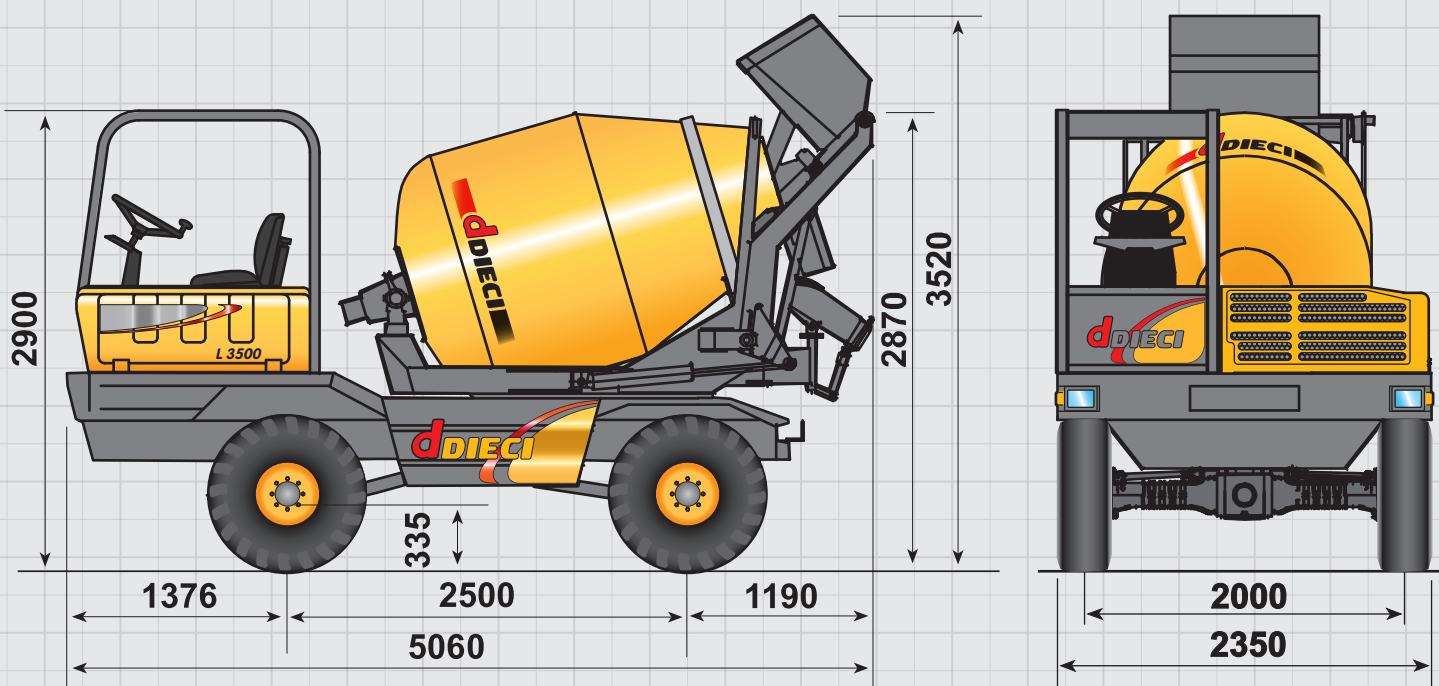

## GENERALITA'

Resa in calcestruzzo:..... 2.50 m<sup>3</sup>  
Carreggiata:..... 2000 mm  
Ruote:..... 12.5 x 18" uso cantiere  
Peso totale a vuoto (con pala di caricamento):..... 6150 Kg  
Peso totale a vuoto (senza pala di caricamento):... 5900 Kg  
Capacità serbatoio acqua:..... 700 l  
Capacità pala di caricamento:..... 500 l  
Velocità massima:..... 27 km/h  
Pompa acqua autoadescente  
Marcatura "CE" - Omologazione per circolazione stradale a carico



## TRASMISSIONE

Pompa idrostatica a portata variabile  
Motore idraulico a 2 velocità a selezione elettrica  
Inversore elettro idraulico azionabile anche con macchina in movimento  
Cambio a 2 velocità servocomandato



## CABINA

Posto guida reversibile.  
Omologazione ROPS - FOPS.  
Sedile regolabile con cinture di sicurezza.  
Vetri anteriori e posteriori - 2 tergicristalli  
**Strumentazione:** indicatore livello carburante - spia olio e temperature acqua - carica batteria.



## DISPOSITIVI DI SICUREZZA

Avviamento solo con marcia in folle.



## MOTORE

Modello:..... IVECO NEF - 4 cilindri - Diesel NA  
Potenza massima:..... 60 kW (82 cv) a 2300 rpm  
Cilindrata:..... 4485 cm<sup>3</sup>  
Iniezione:..... diretta  
Raffreddamento:..... liquido  
Aspirazione:..... naturale



## PONTI DIFFERENZIALI

Tipi di sterzata:..... 4 ruote / trasversale / 2 ruote  
Assali anteriore e posteriore sterzanti con riduttori epicicloidali.  
Assale anteriore autobloccante.  
Frenatura idraulica a dischi in bagno d'olio sulle 4 ruote.  
Freno di stazionamento negativo.



## IMPIANTO IDRAULICO ROTAZIONE TAMBURO

Pompa ad ingranaggi a circuito aperto con regolatore di velocità rotazione tamburo.  
Motoriduttore idraulico coassiale.



## TAMBURO DI IMPASTO

Scarico trilaterale mediante rotazione su ralla.  
Sollevamento tamburo per facilitare lo scarico.

I dati contenuti in questo stampato sono forniti a titolo indicativo; i modelli descritti sono suscettibili di modifiche, senza preavviso, da parte del costruttore, disegni e fotografie possono riferirsi a equipaggiamenti opzionali o ad allestimenti destinati ad altri paesi. Per ogni altra informazione, rivolgersi alla sede DIECI all'indirizzo a fondo scheda.

(Cod. AXE1057 - 02/2007 v1)

DIECI S.r.l.  
Via E. Majorana, 2-4 - 42027 Montecchio Emilia (RE)  
Tel. +39 0522 869611 - Fax +39 0522 869744  
www.dieci.com - mailbox@dieci.com

macchine edili ed agricole  
**d DIECI**  
S.r.l.