

# Dumper

# 1000

Trilaterale

Trilateral

Trilatéral

Dreiseitige

Trilateral



*macchine edili ed agricole*  
**d DIECI**  
S.r.l.



## Dumper 1000 Trilateral



### DETAILS:

Capacity: ..... 2.500 kg  
 Dump body capacity: (level): ..... 1 m<sup>3</sup>  
 Dump body capacity: (heaped): ..... 1,2 m<sup>3</sup>  
 Total weight (empty): ..... 1300 Kg  
 Hydraulic tipping: ..... trilateral  
 Track: ..... 1400 mm  
 Tyres: ..... 7,50 x 16" for construction site  
 Maximum speed: ..... 23 km/h  
 "CE" Marking



### ENGINE:

LOMBARDINI 12 LD 477/2 B1  
 Maximum power: ..... 15 kW (20,4 hp)  
 Displacement: ..... 954 cm<sup>3</sup>  
 Injection: ..... direct  
 Cooling: ..... air  
 Intake: ..... natural



### TRANSMISSION:

4-speed gearbox with reversing gear.  
 Single-plate dry clutch.



### DIFFERENTIAL AXLES:

Differential axles: ..... fixed  
 Brakes: ..... hydraulic  
 Mechanical lever parking brake



### DRIVER'S SEAT:

Instruments: ..... oil temperature light and battery charger  
 Power steering - adjustable seat



### CHASSIS:

Full floating; steering at the centre

The information contained in this publication is merely indicative; the models described may be modified, without notice, by the manufacturer, drawings and photographs may refer to optional or particular equipment for other countries. For any further information, please contact DIECI premises at the address given below.



## Dumper 1000 Trilateral



### GENERALIDADES:

Capacidad: ..... 2.500 kg  
 Capacidad caja: (al ras): ..... 1 m<sup>3</sup>  
 Capacidad caja: (lleno): ..... 1,2 m<sup>3</sup>  
 Peso total vacío: ..... 1300 Kg  
 Vuelco hidráulico: ..... trilateral  
 Distancia entre las ruedas: ..... 1400 mm  
 Ruedas: ..... 7,50 x 16" uso en obra  
 Velocidad máxima: ..... 23 km/h  
 Marca "CE"



### MOTOR:

LOMBARDINI 12 LD 477/2 B1  
 Potencia máxima: ..... 15 kW (20,4 cv)  
 Cilindrada: ..... 954 cm<sup>3</sup>  
 Inyección: ..... directa  
 Enfriamiento: ..... por aire  
 Aspiración: ..... natural



### TRANSMISIÓN:

Cambio ..... 4 marchas con inversor  
 Embrague ..... 1 disco en seco



### PUENTES DIFERENCIALES:

Puentes diferenciales: ..... fijos  
 Frenos: ..... hidráulicos  
 Freno de aparcamiento: ..... mecánico con palanca



### PUESTO DE CONDUCCIÓN:

Instrumentos: ..... luz testigo aceite y carga batería  
 Dirección hidráulica - Asiento regulable.



### CHASIS:

Articulado; viraje en el centro

Los datos presentados en este impreso son proporcionados a título indicativo; los modelos descritos pueden ser modificados sin previo aviso por el fabricante, los dibujos y fotografías pueden referirse a equipamientos opcionales o a equipamientos destinados a otros países. Para cualquier otra información, diríjase al domicilio de DIECI en la dirección al pie de la ficha.



## Dumper 1000 Trilatéral



### CARACTÉRISTIQUES:

Portée: ..... 2.500 kg  
 Contenance caisse (jusqu'à la ligne de faite): ..... 1 m<sup>3</sup>  
 Contenance caisse (à plein charge): ..... 1,2 m<sup>3</sup>  
 Poids total à vide: ..... 1300 Kg  
 Capotage hydraulique: ..... trilatéral  
 Entraxe des roues: ..... 1400 mm  
 Pneus: ..... 7,50 x 16" utilisation sur chantier  
 Vitesse maxi: ..... 23 km/h  
 Marque "CE"



### MOTEUR:

LOMBARDINI 12 LD 477/2 B1  
 Puissance maximum: ..... 15 kW (20,4 cv)  
 Cylindrée: ..... 954 cm<sup>3</sup>  
 Injection: ..... directe  
 Refroidissement: ..... par air  
 Aspiration: ..... naturelle



### TRANSMISSION:

Boîte ..... 4 vitesses avec inverseur  
 Embrayage ..... à un disque à sec



### PONTS DIFFÉRENTIELS:

Ponts différentiels: ..... Fixes  
 Freins: ..... hydrauliques  
 Frein de stationnement: ..... mécanique à levier



### POSTE DE CONDUITE:

Instruments: ..... témoin huile et charge de la batterie  
 Direction hydraulique - Siège réglable



### CHASSIS:

Articulé; avec braquage au centre

Les données contenues sur cet imprimé sont fournies à titre indicatif; les modèles décrits sont susceptibles d'être modifiés, sans préavis, de la part du fabricant; les dessins et les photographies peuvent faire référence à des équipements en option destinés à d'autres pays. Pour toutes autres informations, s'adresser au siège DIECI à l'adresse qui se trouve en bas de la fiche.



## Dumper 1000 Dreiseitenkipper



### BAUEIGENSCHAFTEN:

Tragkraft: ..... 2.500 kg  
 Fassungsvermögen Mulde (glatt): ..... 1 m<sup>3</sup>  
 Fassungsvermögen Mulde (aufgeschüttet): ..... 1,2 m<sup>3</sup>  
 Gesamtleergewicht : ..... 1300 Kg  
 Dreiseitige hydraulische Kippvorrichtung  
 Radstand: ..... 1400 mm  
 Bereifung: ..... 7,50 x 16" für Baustelleneinsatz  
 Max. Geschwindigkeit: ..... 23 km/h  
 "CE"- Kennzeichnung



### MOTOR:

LOMBARDINI 12 LD 477/2 B1  
 Maximale Leistung: ..... 15 kW (20,4 PS)  
 Hubraum: ..... 954 cm<sup>3</sup>  
 Direkte Einspritzung  
 Luftkühlung  
 Selbstansaugung



### ANTRIEB:

4-Gang-Schaltung mit Umschalter  
 Einscheibentrockenkupplung



### DIFFERENTIALACHSEN:

Starr mit hydraulischer Bremse.  
 Mechanische Standbremse.



### FAHRERSITZ:

Instrumentenbrett: Kontrolllampe Öl und Batterieladestand.  
 Hydrolenkung - verstellbarer Sitz



### FAHRGESTELL:

Gelenk, Lenkung mittig.

DIE ANGABEN IN DIESEM HANDBUCH HABEN NUR RICHTWERT. DER HERSTELLER DIECI S.r.l. BEHÄLT SICH DAS RECHT VOR, DIE BESCHRIEBENEN MODELLE OHNE VORANKÜNDIGUNG ZU ÄNDERN. DIE ZEICHNUNGEN UND FOTOS KÖNNEN SICH AUF OPTIONALAUSRÜSTUNGEN ODER FÜR ANDERE LÄNDER BESTIMMTE VORRICHTUNGEN BEZIEHEN. FÜR WEITERE INFORMATIONEN WENDEN SIE SICH BITTE AN DEN SITZ VON DIECI (ANSCHRIFT S. UNTEN).

# Dumper 1000 Trilaterale

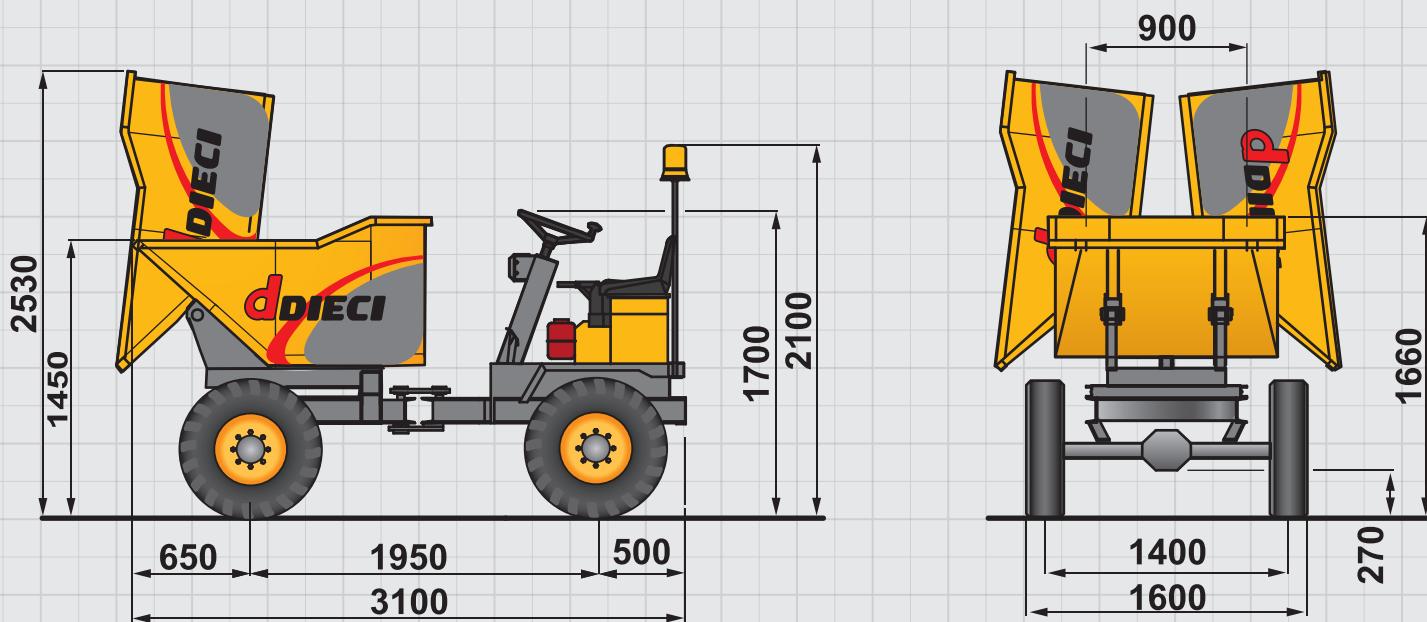

## GENERALITA':

Portata: ..... 2.500 kg  
 Capacità cassone (raso): ..... 1 m<sup>3</sup>  
 Capacità cassone (colmo): ..... 1,2 m<sup>3</sup>  
 Peso totale a vuoto: ..... 1300 Kg  
 Ribaltamento idraulico: ..... trilaterale  
 Carreggiata: ..... 1400 mm  
 Pneumatici: ..... 7,50 x 16" uso cantiere  
 Velocità massima: ..... 23 km/h  
 Marcatura "CE" - Omologazione per circolazione stradale



## MOTORE:

LOMBARDINI 12 LD 477/2 B1  
 Potenza massima: ..... 15 kW (20,4 cv)  
 Cilindrata: ..... 954 cm<sup>3</sup>  
 Iniezione: ..... diretta  
 Raffreddamento: ..... aria  
 Aspirazione: ..... naturale



## TRASMISSIONE:

Cambio ..... 4 marce con invertitore  
 Frizione ..... monodisco a secco



## PONTI DIFFERENZIALI:

Ponti differenziali: ..... fissi  
 Freni: ..... idraulici  
 Freno di stazionamento: ..... meccanico a leva



## POSTO GUIDA:

Strumentazione: ..... spia olio e caricabatteria  
 Idroguida - sedile regolabile



## TELAIO:

Snodato; sterzante al centro

I dati contenuti in questo stampato sono forniti a titolo indicativo; i modelli descritti sono suscettibili di modifiche, senza preavviso, da parte del costruttore, disegni e fotografie possono riferirsi a equipaggiamenti opzionali o ad allestimenti destinati ad altri paesi. Per ogni altra informazione, rivolgersi alla sede DIECI all'indirizzo a fondo scheda.

(Cod. AXE2015 - 02/2007 v1)

**DIECI S.r.l.**  
 Via E. Majorana, 2-4 - 42027 Montecchio Emilia (RE)  
 Tel. +39 0522 869611 - Fax +39 0522 869744  
 www.dieci.com - mailbox@dieci.com

macchine edili ed agricole  
**d DIECI**  
S.r.l.